

## NAGRA CD PLAYERS

Specialists and music lovers consider them amongst the best CD players ever designed



### NAGRA LB RECORDER

Successor to the ARES-C



### NAGRA VI

The new 6-track recorder

## ALLOWING NAGRA USERS to stay at the pinnacle of technology

Since 1951, our company has developed, manufactured and marketed state-of-the-art recorders for the professional audio industry with unflinching success.

tion, power management and electronics have contributed to the reputation of our products from the beginning. Our hi-fi line, which has earned the respect of audiophile community, benefits from this prestigious history.

### EDITORIAL

From magnetic tape recorders to sophisticated digital devices, our company has never ceased to introduce new products addressing the most stringent requirements of sound engineers.

The product line ranges from vacuum tube (valve) pre-amplifiers and amplifiers to solid-state pre-amplifiers and power amplifiers, CD players and D/A converters, to satisfy the most discerning music lovers. Prestigious specialized publications around the world have rated the Nagra CD players amongst the best in the world.

The advent of digital technology has opened the door to new players who have entered the professional audio market by adapting products initially developed for the consumer electronics industry.

Our objective over the next few years is to develop new markets, such as the security and surveillance sectors, and to add new technological features to our recorders, including for example transmission over IP enabling recorded information to be broadcast in the shortest possible time across the globe.



Nagra has made the most of this evolution, offering products that are better targeted to respond to the specific needs that consumer equipment manufacturers are either unable or unwilling to address.

Thanks to our more than 70-strong worldwide distribution network, we deliver unparalleled service quality and technical back-up. Our website, which has received more than 100,000 hits in the last 12 months on both the professional and high-end sections, offers optimal technical support through a variety of tools including FAQs, software bulletins and machine software updates, allowing users to stay at the pinnacle of technology at the click of a mouse.

Our web site, nagraaudio.com, offers even more details on all our products and services. We would be happy to receive any feedback you may wish to share with us.

I would like to take this opportunity to thank our partners and customers for their support and trust, and I look forward to our continued relationship for many years to come. ■

Gérard Beuchat  
Vice-President  
Managing Director

On the hi-fi front, Nagra's equipment inherits the technical know-how in analogue electronics and signal path technology gathered over more than half a century. Our pre-amplifier technology as well as our expertise in power consump-

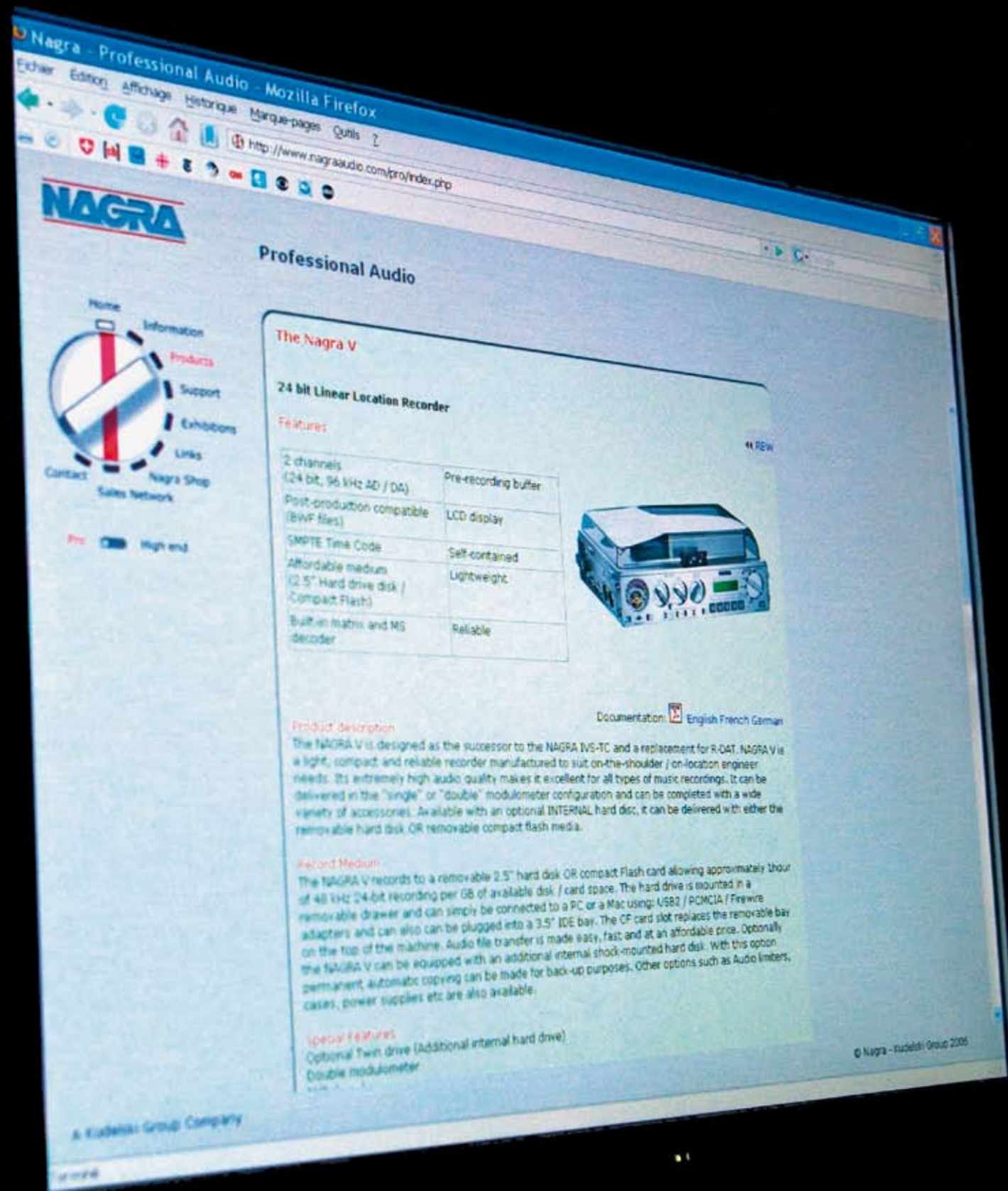

# NAGRA CDC, CDP and CDT

CD players never sounded so good!



The new range of Nagra CD players is a pure expression of the spirit of Nagra. It is born of several developments, mechanical and electronic, already tried and tested in the company's recorders. It boasts many innovative features offering a previously unattained level of performance ▶

Whether in a concert hall or on-location, Nagra is the ultimate yardstick for professional sound recordists seeking to make a recording as close to the original as possible. With Nagra CD players, music lovers are now able to enjoy this sound, reproduced with perfect integrity, in their own system.

## NAGRA CD PLAYERS



### THREE VERSIONS

The range of Nagra CD players comes in three versions:

- The Nagra CDC, equipped with volume and balance controls operating on pre-amplified analogue outputs. This means the equipment can be connected directly to a power amplifier. Another special feature of this model is the double modulometer on the front panel, which allows the monitoring, on each channel, of the signal as it is recorded on the disc.
- The Nagra CDP, which has a fixed level analogue output. The digital-to-analogue converter circuit is identical to that of the CDC model.
- The Nagra CDT, designed for use with an external digital-to-analogue converter such as the Nagra DAC. The front and rear panels are similar on the CDP and CDT models. The brushed aluminium case has the same dimensions as the Nagra PL-P and PL-L pre-amplifiers.

### ABSOLUTE RESPECT FOR THE SIGNAL INTEGRITY

In their engineering and electronics, Nagra CD players set new standards of precision, accuracy and robustness. Engineers have applied a range of solutions aimed at preventing any deterioration in

the signal, all the way from reading the data on the disc to final output from the machine. Special in-depth work has been carried out to solve problems of synchronisation drift (jitter), which typically affects even the best-constructed machines. The results obtained here are spectacular, with negligible values.

An equally rigorous approach has been applied to the construction of circuits, the choice of components and production tolerances. Design consistency ensures exceptional quality.

Great, authentic Nagra sound: a quality which is immediately visible or rather, audible. Never before have CD players reached such levels of clarity, sharpness and natural sound.

### NEUTRALITY AND CLARITY

Nagra CD players are the ultimate reference in terms of electronic engineering and quality of execution.

The signal extracted at the CD module output is completely resynchronised via a PLL (Phase Locked Loop) and a VCXO high-precision oscillator (Voltage Controlled Crystal Oscillator). This dramatically reduces the jitter and the manufacturer code of the disc – data engraved on the CD – retains its integrity.

The digital signal is conveyed symmetrically, eliminating earthing problems. It is received and oversampled by a Burr-Brown digital-to-analogue converter with very low-level noise and distortion. The printed circuit holding the converter is protected against radiation by a gold-plated metal cover.

In order to avoid disruptions linked to the power supply, which is often very pollu-

ted, there are no high voltages or alternating currents inside the machines. The constant +12V voltage, from which the other eight voltages needed by circuits are derived, comes from an external supply box. These voltages are produced by similarly low-noise converters. They are synchronised with the CD module clock.

These technologies, which guarantee perfect clarity and exceptional sound reproduction, are the direct results of solutions developed for Nagra recorders. The same applies to the choice of components, originating from the best sources and selected on the basis of listening tests.

### NAGRA MONOBLOCK TRAY



Nagra CD players are equipped with a front-loading motorised drawer system, which is more practical than the top-loading solutions. However, this entire system has been rethought. Called the "Nagra monoblock tray", it features a CD module mounted directly onto the drawer itself, forming a moving unit.

Built with the same care and attention as a Swiss timepiece, this monoblock unit is particularly sturdy and stable. It provides an ideal mechanised environment for the CD module, a top-of-the-range CD-Pro2M model, to display its full capacity.

The drawer moves on high-precision slides: this achieves a tolerance of only two microns with plenty of smoothness. The drawer is activated by a state-of-the-art planetary reduction motor: a component developed by a NASA-approved supplier, whose products equipped the Mars Rover robot sent to the red planet.

The magnetic clamp that sits on the disc has also been manufactured by Nagra to improve centring and positioning of the CD on the transport. The prescribed weight of this component has been rigorously adhered to; an over-heavy roller would deteriorate the playback and wear the transport motor out prematurely.

The back of the drawer has a diode strip which illuminates the CD when the drawer is opened. This allows the player to be used in reduced light. ■



Nagra CDP and CDT



Nagra CDC



Nagra CDP, CDT and CDC

The connection panel can be either rear or side mounted as desired.

## Technical specifications

Compatibility:	CD Audio, CD-R, CD-RW
Digital-to-analogue converter:	24 bits
Oversampling:	8x (352.8 KHz)
Bandwidth:	20 Hz (0dB) to 20 KHz (-1dB)
Signal-to-noise ratio:	> 108 dB, measured ASA "A" weighted
THD + N:	< 0.003 %
Channel separation:	90 dB
Jitter:	negligible (< 200 ps)
Analogue outputs:	electronically balanced on XLR (600 Ω) unbalanced on RCA (50 Ω)
Output level:	1 or 3.5 V RMS selectable (at 0 dBFS)
Digital outputs:	AES, S/PDIF, Toslink
External supply:	12V
Consumption:	6W constant, 12W maximum
Dimensions:	310 x 254 x 76 mm (12.2 x 10 x 3 inches)
Weight:	4 kg (8.8 lbs)

# NAGRA LB

## Compact and versatile two-channel recorder



The LB is the latest recorder in the Nagra range. It is a two-channel digital recorder designed specifically for the broadcast industry. It supports a combination of features from the rest of the Nagra family making it a very versatile tool for many recording applications.

### SUCCESSOR TO THE ARES C

In brief, it is a portable battery operated 16/24-bit two-channel solid-state recorder with on-board editing, an Ethernet connection and Bluetooth communication. Sampling frequencies of up to 192 kHz are available depending on the application desired.



This compact recorder is designed initially for journalists, with the aim that they can record and edit their material in-the-field and return it to the studio over the GSM network by means of the Bluetooth communication with a mobile phone. The Nagra-LB however fulfils many recording applications from wildlife recording to sound effect gathering and even music productions work. Musicians will find that the features offered on the LB make it ideal for high quality on-location production work. It has the possibility to be connected directly to the internet through its Ethernet port. Files can be immediately transferred over IP, representing an easy way of putting music and other recordings onto the World Wide Web.

In physical size it is marginally larger than the ARES BB+, and runs from eight "AA" cells giving in excess of ten hours recording time.

### FULL OF FEATURES

The microphone inputs are of the highest possible quality and are fitted with a special integrated vortex filter to virtually eliminate wind noise. They are equip-

ped with linkable audio limiters, +48V phantom powering and independent sensitivity selection switches. The XLR microphone input connectors double up as LINE inputs and are conveniently located on the left side of the recorder. An AES digital input can also be fed to a dedicated XLR connector. Also on the left side is the Compact Flash slot, which has a small button next to it marked "Switch", allowing the internal buffer memory to take over the recording duties while the removable card is replaced. The available time for this operation is clearly indicated on the main front display.

The metering and menu displays are accomplished through the back-lit high resolution colour display on the front face of the recorder. In addition there are three LEDs located above each input control as on other ARES recorders, to indicate the presence of signal and overload of each input.

### RUGGED CONSTRUCTION

The front panel of the unit, machined from a solid aluminium block, is laid out in a very simple and easy-to-use manner. The following principal areas merit a mention. First of all the operation of the Nagra-LB is controlled through a traditional rotary main function selection switch with the following positions: RECORD, TEST, OFF, STOP and PLAY, as with other previous Nagra models. The FF and REW as well as SKIP functions are accomplished using easily accessible snap switches next to the function selector. A navigation and execute button, in the centre of the front panel allows easy access and modification of the menu system that is used to select and set the parameters of the recorder.

An internal microphone, that records to both channels simultaneously and ▶▶

## This compact recorder is designed to enable journalists to record and edit their material in-the-field and return it to the studio over the GSM network

### ►► Nagra LB

adjustable headphone output completes the standard features on the front panel.

Recordings are made in either PCM linear or MPEG compressed BWF files and these are recorded to both an internal 2GB fixed memory buffer and an extractable Compact Flash card. One tremendous advantage of the internal buffer memory is not only the ability to allow hot swapping of the card during recording but also to serve as an internal memory for recording, should a replacement card not be available immediately.

### DUAL DISPLAY

The top panel of the Nagra-LB is set aside for the editing features. Thanks to a second colour display and a jog wheel the user can edit audio tracks ergonomically using a combination of the five function keys and the jog wheel. This display gives detailed high definition colour visual indications of the audio waveform being worked on. The top panel also houses the loudspeaker which can be turned on and off as required.

The Nagra LB has a detachable battery compartment into which eight "AA" cells can be fitted. Rechargeable batteries may also be used if desired. External 12V DC can be supplied via the Hirose connector mounted on the left side of the removable battery compartment. This connector is also used to recharge the batteries if fitted with NiMh cells. A lithium-Ion pack is also available as an additional option, using the same battery compartment.

The NAGRA LB has a carrying case, external AC power supply and an adjustable shoulder strap. It is also delivered with a comprehensive operating manual and will be available during 2008. ■



# NAGRA VI

## ANOTHER STEP FORWARD



## THE NEW NAGRA VI SIX-TRACK DIGITAL RECORDER



The development period of a digital audio recorder for the professional cinema, television and music industry lies somewhere between five and ten "man" years depending on how much technology is borrowed from other existing products.

The Nagra VI does have certain elements derived from other Nagra recorders, such as time code, hard disk and compact flash technology but the majority of the machine is entirely new. In terms of the digital platform, upon which all the digital signal processing and command structure is performed, Nagra has implemented a totally new approach. In analogue terms, the line input circuitry and microphone pre-amplifiers, although inspired from the Nagra D and Nagra V are of a totally new design. The recently introduced RoHS requirements were a good reason to redesign all the electronics with the most modern techniques available today.

### THE MOST ADVANCED NAGRA RECORDER EVER

As a result, the Nagra VI, is probably the most advanced recorder, in technical terms, that has ever come out of the Cheseaux factory. The introduction of this new recorder has been anticipated for quite some time and this is a good opportunity to look into the details of the recorder and to answer some of the open questions.

The Nagra VI is, as its name suggests, a six-track recorder. These six tracks are recorded to an internal IDE hard drive. A removable compact flash slot allows either copying of the master recording or copying of various combinations of track selections. The recorder has six analogue inputs on XLR connectors, four of which

are equipped with extremely high quality microphone pre-amplifiers. Two of these connectors double up as AES A and B inputs for connection to digital signal sources.

### FOUR ANALOGUE INPUTS, TWO DIGITAL

Looking in more detail to the microphone pre-amplifiers, they not only offer +48V phantom powering, as one expects, but they are also equipped with in-house wound transformers (when set to the dynamic position) offering an improvement of more than 6dB in the noise floor over the equivalent transformerless inputs.

Fitted with an integrated "vortex" filter, these pre-amplifiers can be used in the windiest conditions imaginable, without suffering from the "popping" traditionally associated with outdoor operation. Naturally this does not eliminate the need for proper microphone protection, but is a great help to the user in unpredictable circumstances. They have been designed to be accurately matched in sensitivity to the various different types of microphones through individual sensitivity selectors for each pre-amplifier.

Digital pots on the front panel give level adjustment to the four pre-amplifiers, while the remaining two analogue inputs can be level set in the menus.

The choice of inputs, along with all other machine parameters, is selected through a clearly laid-out menu system displayed on a 3½" colour TFT screen. This screen has been specially selected as it is "sunlight readable" and has a very large viewing angle. The controlling software for the display has been written in such a manner as to allow the permanent indi-

cation of important information (TC, track, etc.) even when browsing the menus.

Principal operation of the Nagra VI is achieved using the traditional rotary main function selector placed in the standard location on the right side of the front panel. This switch not only follows tradition, but also frees up space on the front panel to allow unimpeded access to other principal controls. The audio tracks can be monitored as required, using a selection of channel switches also located on the front panel, via either of the two ¼" jack headphone connectors.

### TOTAL COMPATIBILITY

The digital portion of the Nagra VI is based on 16/24 bit files recorded in either monophonic or polyphonic Broadcast Wave file formats at sampling frequencies up to 96 kHz with iXML compatible meta data. The time code system covers all traditional SMPTE/EBU frame rates and will allow 0.1% pull down for NTSC compatibility. The 23.976 time code rate is also supported for the modern 24P high definition digital video format compatibility. The entire heart of the Nagra VI is clocked from a Stratum III quartz guaranteeing a maximum drift of less than three ppm throughout the temperature range from -20°C to + 70°C over a 15-year period.

Powering of the recorder is achieved either using external DC or detachable battery boxes containing a choice of different capacity lithium-ion sealed battery packs. The smallest pack offers about four hours operation while the largest in excess of 12 hours. Two female Hirose connectors are located on the left rear side of the unit to allow the powering of

external devices such as RF radio receivers. Without going into detail about every individual feature implemented, all the expected functions such as pre-recording buffer, two M/S decoders, audio limiters, output dithering, chase synchronizing, word clock in /out, analogue and digital outputs have been included.

Two USB ports, one "Host" and one "Device" allow not only the recorder to be connected to a PC/MAC and appear as a generic hard drive for rapid file transfer, but also a multitude of external communication possibilities to be considered.

Nagra engineers feel that the ergonomics of the display and general lay-out of the front panel makes the need for a PC software (as developed for the Nagra D and Nagra V) unnecessary, although the possibility of connecting a PC for diagnostics or input of meta data from an external keyboard are likely future software updates for the host USB port. Any software updates are made by simply downloading the file from our web site onto the CF card, and inserting it into the slot. No recorder ever suits every single application perfectly, but the aim of the development of the Nagra VI was to cover as many bases as possible for

a price that is not prohibitive, while maintaining the Swiss tradition of precision, reliability and excellent performance specifications. ■



On the left and right sides of the machine: Inputs, DC supply and time code connectors, outputs, compact flash slot and communication ports



# NAGRA ARES MII

## Second generation of a benchmark recorder for the broadcast industry

Three years since its market introduction, nearly 6,000 units of the Nagra ARES MII are in use in over 50 different countries. Despite stiff competition from other similar products, the ARES M family has become a benchmark recorder for the broadcast industry.

**EVEN MORE PERFORMANCE IN THE PALM OF YOUR HAND**



This success is due to several reasons, but certainly a contributing factor was implementation of ideas from customer feedback which led us to develop not only software modifications for specific customer requirements, but also a selection of external accessories to adapt the recorders more precisely to the application niches around the globe.

Two such examples are the mono omni-directional clip-on microphone and the green-band stereo cardioid model. These two microphones are entirely made in our Swiss factory, using technical microphone know-how and design experience gained since the microphones for the renowned SN series of miniature open-reel analogue recorders.

### BLUE-BAND MICROPHONE

The mono microphone, with its distinctive blue-band indicator, is specifically designed for broadcast journalism and in terms of use, allows the operator to gather interviews without "pointing" the microphone (and machine) directly at the subject, which can often cause discomfort and distraction. It offers excellent low frequency response, is very insensitive to wind noise and is thus ideal for "street" reporting, giving true feeling of space and reality to in-the-field recordings.

As can be clearly seen from the diagram, the mono microphone gives excellent linearity throughout the audio spectrum

and has become the preferred microphone for many broadcasters. Interestingly enough, many customers have opted for the green-banded stereo version as their microphone of choice. In contrast to the mono omni-directional microphone, it is fitted with two cardioid capsules mounted in an ">" formation at an angle of 90° to one another.

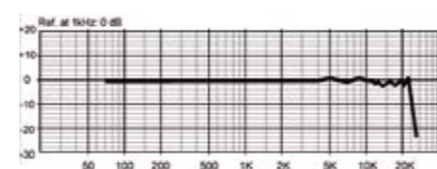

Typical frequency response of the mono capsule

### GREEN-BAND MICROPHONE

The performance of this microphone is obviously different to that of the omni and naturally, being a cardioid microphone, it is more susceptible to artifacts such as wind noise and the proximity effect. This stereo microphone offers a good left / right separation and is widely used for stereo music recording, sound effects gathering and interview situations where the participants are clearly placed opposite to each other. The technical characteristics of the stereo microphone are shown in the table below.

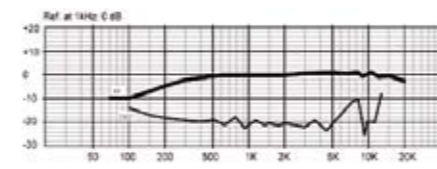

Typical frequency response of the stereo capsule

The thick line on the accompanying graphic represents the sensitivity when the source is directly in front (or above) the microphone, whereas the thinner line (below) shows the sensitivity when

the source is located behind the capsule. It has become clear, in conclusion, that simply building a recorder is not enough to satisfy the wide ranging requirements of the recording industry.

Nagra has the ability not only to offer the complete solution but also to be attentive towards the resolution of in-the-field technical issues, often associated with modern computer based platforms. ■



The Nagra ARES-MII is delivered with a standard red-band stereo microphone

### BLUE-BAND OPTIONAL MICROPHONE SPECIFICATIONS

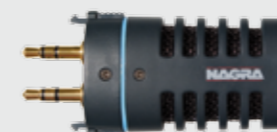

Blue-band mono microphone is omni-directional. It allows to gather interviews without "pointing" the machine directly at the subject

Capsule type	Electret condenser
Termination	Mini jack 3.5 mm male
Directionality	Omnidirectional
Signal-to-noise ratio	≥ 45 dBA for 74 dBA
Operating voltage	3 V
Supply current	< 400 µA
Weight	18 grams
Impedance at 1 kHz	1.6 kΩ ± 30 % (R1 = 2 kΩ)
Sensitivity	15.8 mV/Pa or -36 dB ± 2 dB
Maximum input level	115 dB SPL
Temperature range	- 10° to + 60°
Storage temperature	- 20° to + 70°

### GREEN-BAND OPTIONAL MICROPHONE SPECIFICATIONS

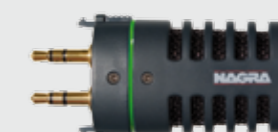

Green-band cardioid stereo microphone

Capsule type	Electret condenser
Termination	Mini jack 3.5 mm male
Directionality	Cardioid
Signal-to-noise ratio	≥ 48 dBA for 74 dBA
Front/rear ratio	≥ 12 dB (180° ± 45°)
Operating voltage	3 V
Supply current	< 400 µA
Weight	18 grams
Impedance at 1 kHz	1.8 kΩ ± 30 % (R1 = 2 kΩ)
Sensitivity	14 mV/Pa ± 3 dB/Pa
Maximum input level	110 dB SPL
Temperature range	- 20° to + 50°
Storage temperature	- 30° to + 60°

## NAGRA VPS

State-of-the-art phono valve pre-amplifier to extract the full potential of vinyl disks



Against all the odds, the appearance of the compact disk in 1983 has not led to the death of vinyl. Despite the many advantages of the digital medium, the analogue disk retains many enthusiasts committed to its special sound qualities: a sound texture considered to be warmer, more human and closer to the "live" environment.

### NAGRA VPS PHONO VALVE PRE-AMPLIFIER



Even if the vinyl disk now represents only a niche market, this is far from negligible. It has even experienced a renewed vitality in recent years.

The sale of used LPs remains very buoyant and carefully pressed reissues regularly appear. New models of turntable decks and cartridges, often very sophisticated, are constantly appearing on the market, and attest to the fact that music lovers continue to invest large sums to get the most out of their analogue disk collections and take advantage of technical improvements in reproduction equipment.

The situation is less clear as regards the electronic equipment. Present day systems, even high-end, rarely have a phono section integrated into the pre-amplifier and when they have, it is often of average quality.

This situation prompted Nagra to introduce, a few years ago, the PL-P valve pre-amplifier with a very high-quality phono section. This device has become a global benchmark. But for music lovers who want simply to add an autonomous phono pre-amplifier to an existing installation, an adequate solution still remained to be developed. ▶▶

### ►► TO THE ABSOLUTE LIMIT

The design approach has been to reuse the base of the phono section of the PL-P pre-amplifier and, retaining the best of this circuit, to carry its development to the absolute limit under all criteria. The result is uncompromising and leads to a listening quality where the magic of the LPs is fully reproduced.

The Nagra VPS is also ideal for those who want to digitize their LPs and to avoid the deterioration of the signal introduced by a phono pre-amplifier of poor quality in the equipment effecting the transfer.

### MODULAR AND CONFIGURABLE INPUT BOARD

The input boards are designed in a modular fashion, thereby giving the user the ability to freely configure the unit depending on the upstream equipment: turntable deck(s) with moving coil (MC), or moving magnet (MM) cartridges. The standard version of the VPS comes with an input circuit for MC provided with transformers which can be switched (bypassing the transformers) to an MM input thanks to a system of jumpers.

The device can also be provided with an optional second circuit for MM or MC input (this circuit has no transformers).

To achieve maximum performance, it is imperative that the impedance matching between the cartridge and the input circuit be perfect. In order to control this aspect, Nagra engineers have developed a set of small modular circuits each corresponding to a given impedance.

The choice of module to plug into the input board depends on the value prescribed by the manufacturer of the cartridge. The impedance module is also activated with the aid of a jumper.

The impedance module and the jumpers are placed very close to the input connectors so as to minimize the signal path. They thus avoid the antenna effect to which phono pre-amplifier signals are very sensitive, given the very weak signal levels involved.

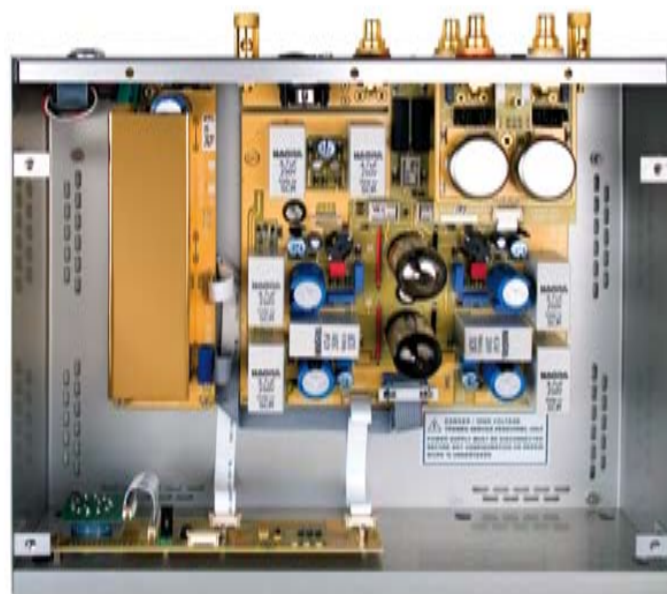

Inside The Nagra VPS: a modular conception and top quality components for uncompromising results

Six standard modules are supplied with the unit (three resistive and three capacitive) and three others are supplied free upon request, according to the requirements of the purchaser.

### INPUT TRANSFORMERS MADE BY NAGRA

The input transformers on the MC board play a critical role in the performance and overall musicality of the unit. Those of the VPS are designed and wound by

Nagra, as are those that equip the microphone inputs, also highly sensitive, on the brand's recorders. The company thus possesses an exceptional experience in the manufacture of these very difficult-to-develop components.

The VPS input transformers have been newly developed and are therefore different from those that equip the Nagra PL-P pre-amplifiers. Their magnetic core uses glass-metal, as used in the audio heads of tape recorders. The performance has improved in several ways: better linearity, significantly extended saturation threshold, greater comfort in the low frequencies.

The transformers are protected from parasitic interference by a cover in annealed  $\mu$ -metal. They provide a gain of 11dB, thus making superfluous a first amplification stage at the floating MC input.

### MAIN CIRCUIT OF THE GAIN STAGE

The main amplifier circuit has two stages. The first, which provides a gain of 34dB, is built around two double triode valves, one type ECC81 and one ECC83, rigorously selected and matched. For this selection, Nagra uses a test bench on which valves are tested for 48 hours (burn-in process). 80% of the valves tested are rejected and only 20% manage to reach the noise and performance standards set by the engineers. Nagra estimates the useful life of the valves chosen at more than 5,000 hours. Each channel of this first stage has a jumper allowing a choice between two RIAA

curves. With jumpers in place, it is the RIAA 1953 curve that is applied, offering the greatest bandwidth. With jumpers removed, it is the 1976 curve that is used, with an attenuation below 90Hz. This setting makes sense when the turntable generates low-frequency noise, as is often the case with "average" turntables.

The second stage of amplification, with separate components, can be activated or not by using a switch on the rear panel. It provides an additional gain of 15dB. This extremely silent circuit is based on Nagra designs for microphone pre-amplifier circuits.

With two levels of output, 300 mV for the low level and 2V for the high level, the user can perfectly adapt the Nagra VPS to the sensitivity of his/her downstream equipment.

The amplification circuit board is mounted on amortized suspensions to filter out vibrations and limit microphonic effects on valves and components. The V-shaped ground plane has been particularly studied to avoid any parasitic effects.

### POWER SUPPLY CIRCUIT

The power supply circuit has the task of providing the different voltages required for the valves (high voltage) and the circuits. It is fed from +12V that is provided by the external AC power supply. Nagra uses switching power supply technology, an area where the company also has long experience. The transistors of the second output stage are filtered and fed separately. A gold-plated shielding hood covers the circuit and avoids radiation to other circuits.

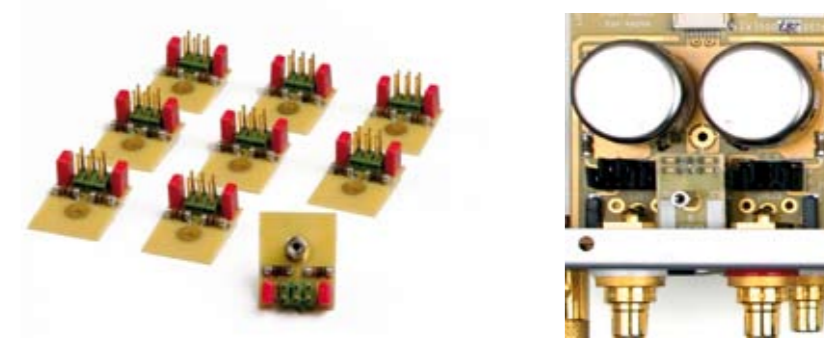

The impedance modules for a perfect matching between the cartridge and the input circuit

MC board with Nagra made input transformers, the matched impedance module and the jumpers setting

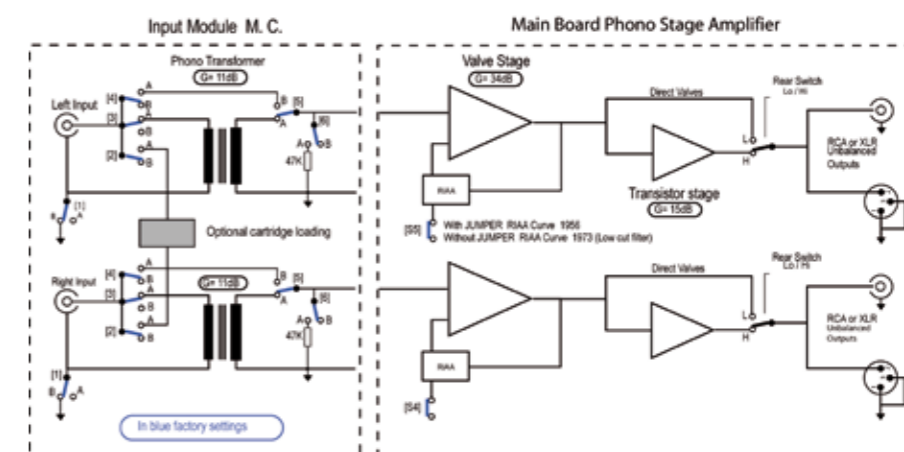

Block schematic of the Nagra VPS phono pre-amplifier

### CONTROL CIRCUIT

Just behind the front of the unit, the control circuit handles the functions activated by the rotary selector. It is equipped with a microprocessor managing the soft-start valves, the mute function and standby. Thus, when the power is switched on, the Nagra VPS provides pre-heating: it feeds the filaments of the valves, but waits 2 minutes before applying the high voltage to the anodes. It also memorizes the last shut down and does not re-apply the pre-heating procedure if the shut down is of short duration.

When the user activates the switch to pass from one input to another, a relay cuts the input for three seconds to avoid switching noise. During normal operation, the relays are in the rest position to allow the passage of the signal.

The relays are activated when the signal is to be cut. This ensures that the vibration of the relay blades is not communicated to the signal when they are powered. ■

## GOOD RECORDING: Do the “numbers” add-up?

In the days of analogue tape, recordings were not only dependent upon the quality of the recorder, pre-amplifiers and microphones but also on the limitations of the recording tape.

Artifacts such as wow and flutter, tape "hiss", even print-through along with limitations of distortion, equalization and bias had tremendous effects on the quality of recordings, not to mention the alignment of the tape transports, as often tapes were recorded on one machine and played back on another.

### TECHNICAL DISCUSSION



Today, thanks to digital technologies, all of these media and transport related problems have been removed, and the quality relies more heavily on other parameters, which are often either misunderstood or simply ignored. For example there is a common perception today that a "better" recording will result if a recorder capable of making 24 bit 96kHz recordings is used instead of one operating at 16 bit 44.1 kHz. Without trying to define "a better recording" it is interesting to look at the critical factors behind such a presumption.

### WORD LENGTH AND SAMPLING FREQUENCY

The word length 16, 18, 20 or 24 bits can be related to two specific areas of the recording chain: Firstly the word length used by the A/D when digitizing the analogue signal, and secondly the word length which is actually recorded on the media. The latter needs to be at least equal to the A/D in the record chain, however it is perfectly reasonable to record a 24-bit word length derived from a 20 or even 16 bit A/D converter. In such a case the least significant bits (LSB's) will simply be recorded as "0's" and will serve

purely to make the bit stream compatible with other equipment of the same format, but will have no bearing on the audio quality. Therefore to assume that a 24 bit audio signal was created using a 24 bit A/D converter is purely hypothetical.

Concerning the sampling frequency which is chosen, there have been many studies arguing the virtues of higher sampling frequencies, and without side tracking too much, it is safe to say that the more audio information that is recorded at the outset, the better the chance of restituting the original sound later, becomes. It is perhaps simply better to decide which sampling frequency to use depending on each particular recording.

### WHAT REALLY INFLUENCES A GOOD RECORDING?

It should be remembered that sound is generated as an analogue signal and is perceived by the human ear as an analogue signal. Several critical factors such as microphone choice, placement and recording environment are far more important than the word length and sampling frequency or even the recorder chosen. But, assuming these practical factors are well understood, then the last remaining factor, as far as a recorder are concerned, is the audio chain itself in terms of level, frequency response and dynamic range.

These factors in themselves have an equally important bearing on the recording, and if misunderstood or misused can produce poor recordings even with the best recording equipment.

### LEVEL SETTING

Level is probably one of the most difficult points to discuss as there is no "golden rule" or formula for setting it, and the setting will have a bearing on the quality of the recorded sound. It is however important to remember that unlike the old analogue days when a signal peaking comfortably at +3 or +6dB above maximum level was quite normal, where the gentle progressive distortion introduced, gave warmth and depth to the recording. In the digital world this is impossible as digital chains do not allow this approach

## Several critical factors such as microphone choice, placement and recording environment are far more important than the word length and sampling frequency

and therefore level setting is far more critical than in the past. A digital signal cannot get "louder" than 0 dB or in digital terms "7FFF" for a 16-bit sample, and once this point is reached distortion produced is total.

So in principle, one tries to record as close to this point as possible, without going over it to ensure maximum use of the available dynamic range of the digital system. In reality though, as the generally accepted tone reference is -18 dB the peaks will be around -10 dB at best. This insinuates that the average or mean audio level will probably be some 6 - 8 dB below this, i.e. around the -16 to -18 dB point.

Now, as the useable dynamic range in digital terms is calculated at 6 dB per bit, a 16 bit system should have a usable dynamic range of 96 dB (although in reality this equates to about 90 dB),

starting from the "0" point, and counting back to -90 dB. If the recording level is peaking at around -10dB then the maximum available dynamic range is only in fact about 80 dB. In this scenario, with the best will in the world, you are only making a 13-14bit recording.

### THE MICROPHONE PREAMPLIFIER STAGE

If we now look at the microphone pre-amplifier stages, a dynamic range of 120 dB can be considered as the best currently available in any audio recorder,

and therefore, using this to its absolute maximum ability your digital level is only going to brush the 20 bit mark, so one could argue as to the advantage of using 24 bits, in audio terms is somewhat academic.

This being said, if one looks at a microphone pre-amplifier stage and sees that its dynamic range is limited to say 85 dB, there seems little point in worrying whether the recording is 16, 18, 20 or 24 bit and it will make absolutely no difference to the "quality" of the recording.

A frequent comment is "Using external 24/96 converters makes it sound so much better". Well, in fact, this is purely because such external converters are relatively expensive pieces of equipment, and contain high quality analogue stages. Hence the subjective improvement has little to do with the number of bits or sampling frequency.

The sampling frequency and frequency response go hand-in-hand really, and although using the Nyquist theory, 44.1 kHz is sufficient to record perfectly up to 22.05 kHz bandwidth, using higher sampling frequencies does appear to reconstitute the original sound more accurately.

### A COMBINATION OF ART AND SCIENCE

In conclusion, sound recording is a combination of art and science, and many years experience enables the correct choices of equipment to be made for any particular recording, but complicated technical explanations, often imply that better recordings are made using certain technologies. However, the quality and positioning of the microphones, the analogue pre-amplifiers and their useable dynamic range is far more important than the digital word length or sampling frequency.

Some manufacturers will encourage the belief that these technical specifications are of critical importance when, in fact, much of the time they are completely irrelevant. This may simply be because it is relatively easy to design circuits using high bit depth converters at high sampling frequencies, rather than designing analogue microphone pre-amplifiers with high gain, wide dynamic range and low distortion.

The best way to judge a piece of equipment is to listen to the recording. ■  
John Owens



## Original and fascinating look Magnificent, natural, unrestricted sound

The NAGRA pyramid amplifiers exist in two versions: the PMA monoblock units, offering 200 W into 8 ohms, and the PSA stereo amplifier, delivering 100 W per channel.

These amplifiers guarantee an outstanding audio reproduction quality. With them, music fully expresses its personality in a rich, lively and totally transparent manner.

This is the success of the PMA and PSA amplifiers: technology slides into the background to make way for emotion.

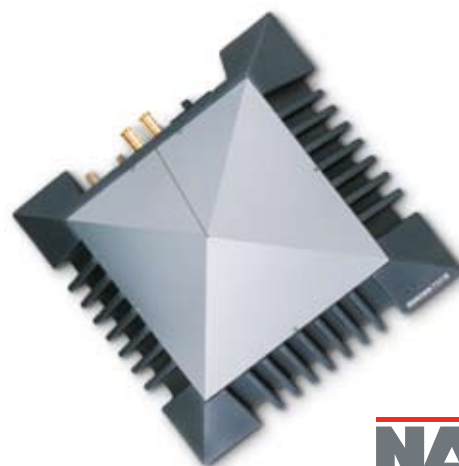

Bandwidth: 10 Hz to 70 kHz, +0 / -3 dB. Total harmonic distortion: less than 0,09%.  
Channel separation (PSA), better than 85 dB. Signal-to-noise ratio: typically 104 dB.

**NAGRA**  
Swiss made